



TruMatic:

The perfect  
combination.

# Combining forces to achieve success.

## Contents

Combining forces to achieve success. _____	2
Profiting from versatility. _____	4
Intelligent punching. _____	6
Punching tools and accessories. _____	7
<b>TruMatic 3000 fiber</b> _____	8
<b>TruMatic 6000</b> _____	12
<b>TruMatic 6000 fiber</b> _____	16
<b>TruMatic 7000</b> _____	20
Components that pay off. _____	24
Programmed for success. _____	26
TruServices: Service like no other. _____	27

TruMatic machines combine all the benefits of punching and laser processing. They enable you to produce a broad range of parts and handle even the most challenging jobs successfully. The punching head performs standard contouring and forming tasks, while complex contours are cut by the laser.

In 1979, TRUMPF became the first company to offer this combined technology to its customers. We have been building our own lasers for the industrial manufacturing industry since 1985 and have steadily established ourselves as a world leader in this sector.

## TruMatic: Benefits at a glance.

- 1 Enhancing your capabilities through a mix of technologies.
- 2 Standard contouring and forming tasks are performed by the punching head.
- 3 The laser produces high-quality results for flowing and irregular contours.
- 4 Exceptional part quality.
- 5 Reduced non-productive times thanks to the one-cutting-head strategy.





### TruMatic 3000 fiber

**Compact thin-sheet-processing machine.** This highly versatile machine enables the profitable processing of thin sheets and the cost-effective entry into laser welding.



### TruMatic 6000

**Robust universal machine.** This machine masters every task with reliability and productivity – and its whole performance can be activated quickly and simply.



### TruMatic 6000 fiber

**Productive thin-sheet-processing machine.** From steel to aluminum to highly reflective materials such as copper or brass: with its solid-state laser, the thin-sheet specialist processes the complete range of materials with high productivity.



### TruMatic 7000

**Productive high-end machine.** Dynamic, scratch-free and fast – this top-rated combination machine fulfills the most stringent requirements with regard to productivity and part quality.

## Profiting from versatility.

Standard contouring and forming tasks are performed by the punching head.



In addition to punching holes, you can produce three-dimensional contours such as brackets, threads and other forms. The electro-hydraulic punching head takes complete charge of processing your parts, eliminating the need for most downstream processing steps. Other benefits include:

- Versatile and cost-efficient thanks to 360° tool rotation.
- Produces a wide range of forms.
- High-speed processing.
- Top-notch punch contours.
- Fast changeover times.

The laser produces high-quality results for flowing and irregular contours.



Nothing beats lasers when it comes to cutting high-grade outer contours and intricate inner contours. With the slimline laser head of a TruMatic, you can cut right next to formed areas – or even cut on top of them. Controlline maintains a constant distance between the sheet and the cutting nozzle, resulting in a highly reliable process for fabricating even the most unusual geometries.

- Our lasers provide extraordinary versatility.
- Excellent cut quality.
- Sheets up to 8 mm thickness.
- Intricate contours.
- Our lasers are extremely energy-efficient.

Stable yet easily accessible.



All TruMatic machines are manufactured in an open C-frame design which gives you access to both the machine and the workpiece from three sides. With this configuration there is plenty of room for both manual and automated loading and unloading. Our machines are extraordinarily stable, ensuring high levels of accuracy and a long service life.

- Machine is easily accessible from three sides.
- High accuracy levels.
- High-speed unloading through parts chute.
- Modular automation.

## Intelligent punching.

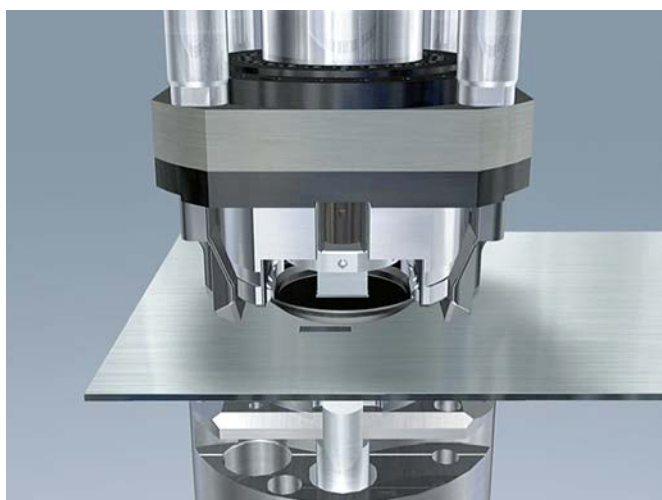

The wear-free ram guidance system combined with the mechanism that actively retracts the punch ensures accurate results and maximum process reliability.



Thanks to 360° rotation, you can punch at whatever angle you like.

### Versatile and cost-efficient thanks to 360° tool rotation.

Tools fit snugly into the punching head. One of the greatest advantages of the head design is that it can rotate any tool to the angle that is required, regardless of the tool's shape, size or position in the magazine.

#### Benefits of 360° rotation at a glance.

- Ability to position tools at any angle.
- More efficient use of materials thanks to versatile sheet layout.
- Lower number of necessary tools.
- Fast changeover times.
- Lower tool investment is necessary.

# Punching tools and accessories.

## Wide selection of high-quality punching tools.

For over 40 years, TRUMPF has been providing its customers with top-quality punching tools and much more besides. No matter what challenges you face, we can offer you a range of support – from technical consulting to design assistance, right on to the prompt delivery of your tools.

- **Punching tools:** Within our leading tool system, Classic, we offer a wide range of shapes and coatings as well as free punch shears. With EasyUse in the standard equipment offer, easy setup is guaranteed.
- **Slitting tools:** Simple separation contours, the cutting of formed areas or visible edges without nibbling marks can all be performed flexibly and inexpensively.
- **Forming tools:** By forming the sheet plastically you can do a variety of forming operations. TRUMPF tools enable you to perform the complete processing spectrum reliably on one machine. A very high processing speed and part quality without any visible forming marks can be achieved by using roller technology. Furthermore, we also offer you the appropriate solution for specialized applications such as deburring.
- **Embossing and marking tools:** Whether you are looking to inscribe serial numbers, the year of manufacture or your corporate logo, we can provide the tools you need for fast and efficient marking.
- **Tooling accessories:** Make set-up and maintenance easier and increase the service life of your tools. Achieve optimal results with precisely calibrated and perfectly sharpened tools.



Slitting tool MultiShear.



Roller deburring tool.

# TruMatic 6000

Robust universal machine.

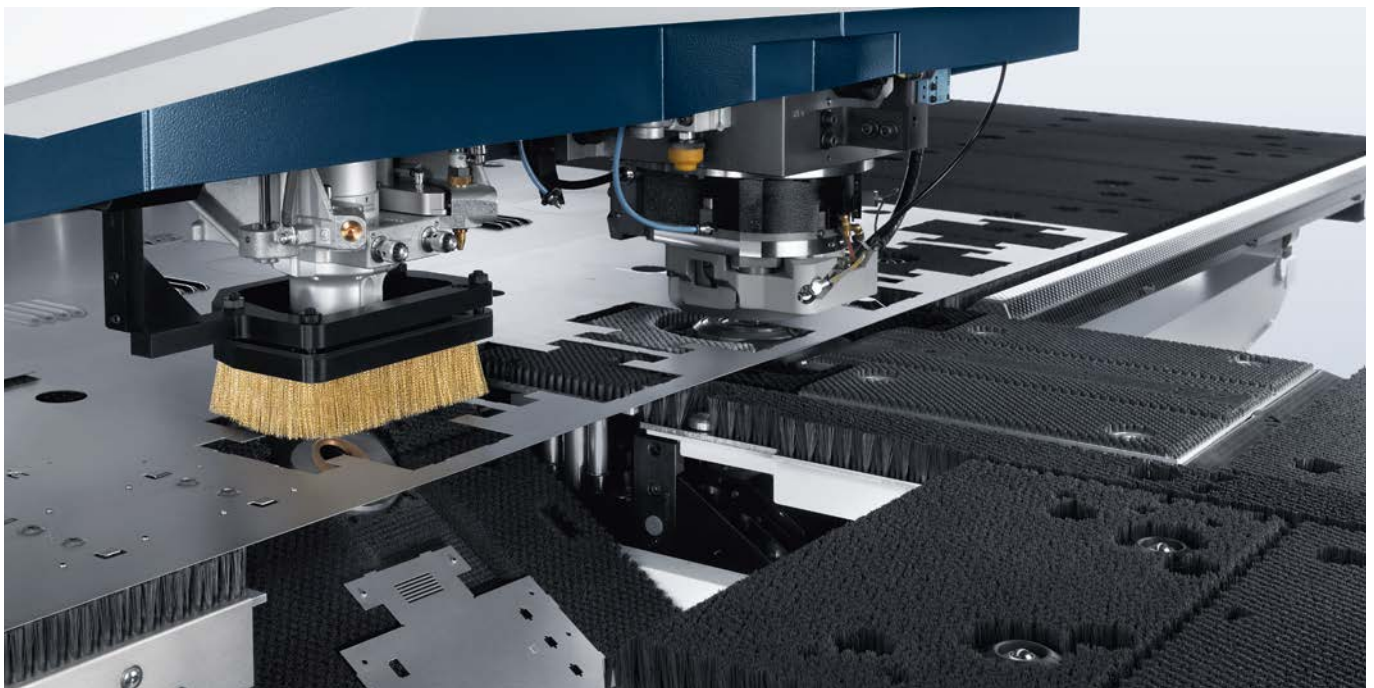

TruMatic 6000:  
Benefits at a glance.

- 1 A technically mature machine concept and intelligent software functions provide the highest level of process reliability.
- 2 Scratch-free processing.
- 3 Automated tool changing.
- 4 Outstanding energy consumption through ingenious laser concept and universal cooling interface.
- 5 Simple operating concept.

With the TruMatic 6000 you have an especially versatile machine with technically mature laser and punching technologies. The high power of the punching head and laser guarantee high productivity.

And an ingenious laser concept and various options provide high energy efficiency. You can activate the power of the machine quickly and without complication because of its simple operating concept.



## Producing with process reliability.

A number of intelligent machine and software functions such as the descending die and punch monitoring make the TruMatic 6000 extraordinarily process-reliable. In this way, you can produce at night and on the weekend without interruption.

## The highest part quality without restrictions.

The machine can be equipped with proven options, with which you can get the best results. The brush table, descending die and part removal flap with brushes guarantee scratch-free processing throughout the entire production process.

## Minimized non-productive times.

Optimized cycles within the machine control enable very quick tool changes. The speed of the optional automation solutions is increased at the same time.



The integrated tool changer on the SheetMaster simplifies the exchange of tools and, what is more, is designed to be particularly space-saving.

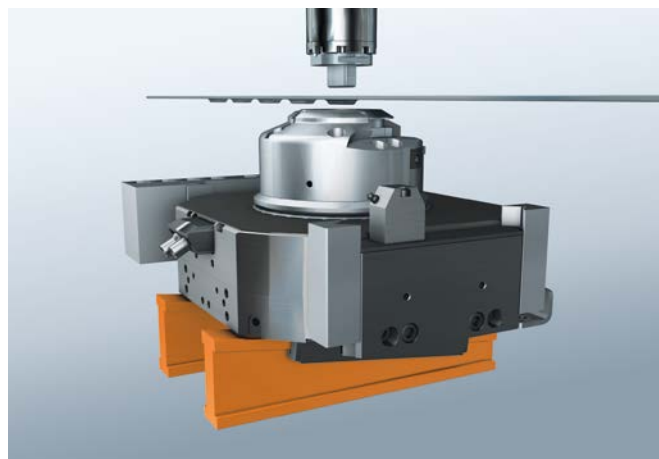

The descending die allows for scratch-free punching and forming, and expands the possibilities of downward forming.



#### Technical specifications:

	TruMatic 6000 medium format	TruMatic 6000 large format
<b>Work area (X x Y)</b>		
Combined punch/ laser operation	2500 x 1250 mm	3050 x 1550 mm <sup>[1]</sup>
Punching operation	2500 x 1250 mm	3050 x 1550 mm
Laser operation	2500 x 1250 mm	3050 x 1550 mm
<b>Capacity</b>		
Laser power	2000 / 2700 / 3200 W	2000 / 2700 / 3200 W
Max. sheet thickness	8 mm	8 mm
Max. punching force	180 kN	180 kN
Active hold-down (programmable in steps)	4.5 – 20 kN	4.5 – 20 kN
Max. workpiece weight	230 kg	230 kg
<b>Speed</b>		
X axis	90 m/min	90 m/min
Y axis	60 m/min	60 m/min
Simultaneous (X and Y)	108 m/min	108 m/min

#### Speed

C axis (punching)

C axis (tapping)

Max. stroke rate (punching)  
(E = 1 mm)

Max. stroke rate (marking)

#### Tools

Linear magazine

No. with MultiTool

MultiTool

#### Tool change time

#### Accuracy<sup>[2]</sup>

Positioning accuracy Pa

Repeatability Ps



TruMatic 6000 medium format	TruMatic 6000 large format
330 rpm	330 rpm
330 rpm	330 rpm
1000 1/min	900 1/min
2800 1/min	2800 1/min
23 tools with 2 clamps	22 tools with 3 clamps
23–230	22–220
5/10 station	5/10 station
0.3–3.2 s	0.3–3.2 s
± 0.10 mm	± 0.10 mm
± 0.03 mm	± 0.03 mm

	TruMatic 6000 medium format	TruMatic 6000 large format
TRUMPF CNC control	Basis Rexroth IndraMotion MTX	Basis Rexroth IndraMotion MTX
<b>Programmable chute</b>		
Max. part size for punch and laser	500 x 500 mm	500 x 500 mm
<b>Dimensions<sup>[3]</sup></b>		
Space requirements	8000 x 7165 mm	8333 x 7990 mm
Height	2710 mm	2710 mm
Weight	16000 kg	21000 kg

<sup>[1]</sup> With repositioning.

<sup>[2]</sup> Achievable workpiece accuracy depends on various factors, including workpiece type, its pretreatment, sheet size and position within the work area. In accordance with VDI/DGQ 3441. Measuring length 1 m.

<sup>[3]</sup> Approximate values. Exact specifications can be found in the most recent installation plan. Subject to alteration. Only specifications in our offer and order confirmation are binding.



Automation:

## Components that pay off.

Profitable and efficient production with automation options from TRUMPF.

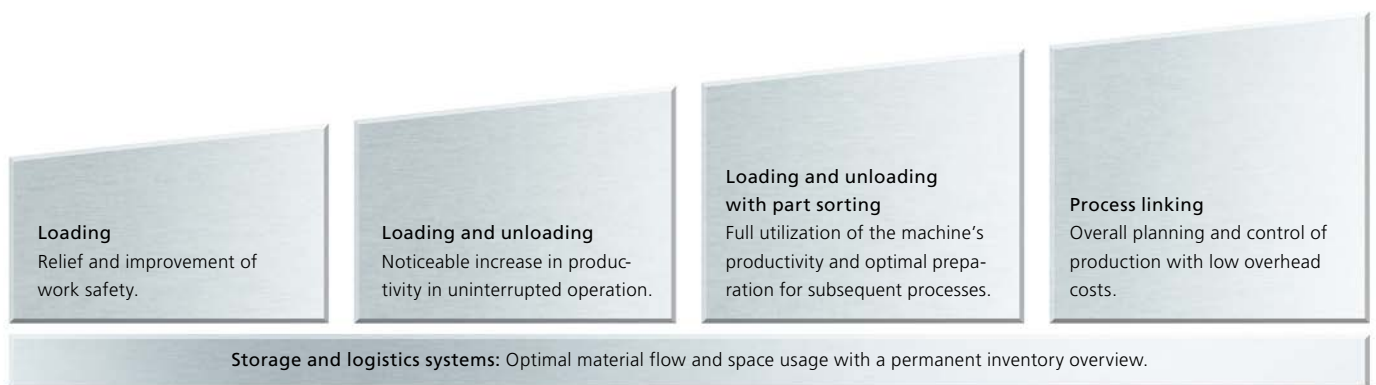
Automated machines support the material flow, increase process reliability and enhance productivity. TRUMPF's multi-stage concept offers automation that meets your individual needs – all the way through to completely automated production. The solutions come from a single source and are perfectly tailored to TRUMPF machines.

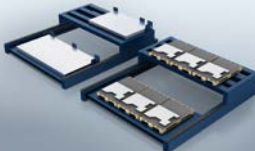
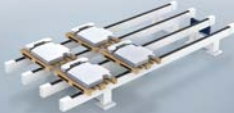

	SheetMaster	Cart systems	SortMaster Pallet	SortMaster Box
				

**Compatible machines:**

TruMatic 3000 fiber	■	■	■	■
TruMatic 6000	■	■	■	■
TruMatic 6000 fiber	■	■	■	■
TruMatic 7000	■	■	■	■

<sup>[1]</sup> SheetMaster with integrated tool changer <sup>[2]</sup> ToolMaster

**SheetMaster:** Fast and reliable loading and unloading, stacking and sorting.

**Cart systems:** Double your loading and unloading capacity by deploying versatile storage and sorting solutions for raw materials and finished parts. Solutions with tracks and belt drives are available.

**SortMaster Pallet:** Sort and stack finished parts on up to six europallets.

**SortMaster Box:** Sort finished parts into four standardized, stackable containers.





**GripMaster:** Fast and reliable removal and stacking of sheet skeletons parallel to the loading process.

**ShearMaster:** Shredding of sheet skeletons during machining operations minimizes process costs in the manufacturing environment.

**Tool changer:** The ToolMaster can load tools particularly fast and expands your capacity by up to 70 tool stations. The SheetMaster with an integrated tool changer offers 40 additional tool stations and a gripper integrated in the suction frame which automatically loads tools onto the linear magazine of the machine.

**TruStore:** Modular and upgradable storage and shelving system provides a well-organized, space-saving storage solution.

**Large Storage Systems:** For special requirements we also offer highly customizable storage solutions in cooperation with our partner, Stopa.

GripMaster	ShearMaster	Tool changer	TruStore	Large Storage Systems
				
■			■	■
■		■ [1]	■	■
■		■ [1] or [2]	■	■
■	■	■ [2]	■	■

Software:

Programmed  
for success.



TruTops Boost takes you faster than ever from the geometry to the NC program.

TRUMPF's TruTops Boost is the software solution for designing and programming laser, punching and bending machines that lets you increase your performance at the touch of a button. The software combines all order processing steps, from the geometry through to the completed NC program, in a single all-in-one solution. Its intuitive operating philosophy guides you through the software in a simple, process-oriented manner while allowing you to keep an overview of your orders. Thanks to its numerous automated functions, the innovative Boost technology also makes you unbeatably fast. With it, you become more profitable and boost your business!

Talk to your TRUMPF contact to find out when TruTops Boost will be available to you. Until then, our TruTops Punch software can offer you optimum support. We recommend our TruTops Fab software as the ideal production control system for your requirements.

TruTops Boost: Your benefits at a glance.

- From geometry to NC program faster than ever before.
- Everything monitored: Single software solution for all order processes.
- Everything under control: Intuitive user interface supports flexible working.
- Everything faster: Boost technology with productive automated functions.
- Innovative Boost technology + new operating philosophy = TruTops Boost

TruServices:

Service like  
no other.

Throughout the lifecycle of your machine.

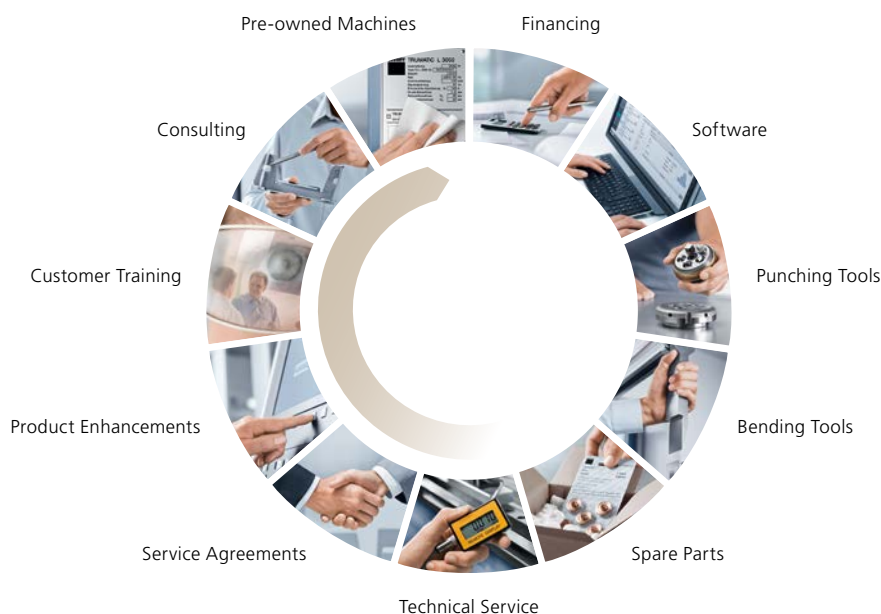

Regardless of the TRUMPF technology you use, you will always get the best service. Thanks to the award-winning spare parts logistics at TRUMPF, we guarantee the highest availability of spare parts and provide you with all the products in the shortest time. TRUMPF offers you individual financing solutions quickly and without a lot of paperwork. Our service technicians are highly trained and always available when you need them. A Service Agreement is the ideal way of ensuring the highest availability of your machine. Should your requirements change,

we have flexible upgrading options and technical innovations that will make your machine even better. Our broad range of training courses with experienced trainers and hands-on practice will also give you a head start in understanding and operating your machine.

The TRUMPF Group ranks among the world's leading manufacturers of production technology and industrial lasers. Technical and efficient solutions for our customers have been our focus since 1923. As a leading technology supplier, TRUMPF is a one-stop shop for all of your technology needs: machines, automation, storage technology and services.

TRUMPF is certified according to ISO 9001:2008  
(for further information see [www.trumpf.com/en/quality](http://www.trumpf.com/en/quality))

Ident no. 0372732\_201410\_F – Subject to change